

Buzz Wire

A. SAFETY MESSAGES

1. Please read through this instruction before you start.
2. This kit is intended for age 8 and up.
3. Adults assistance and supervision required during assembly.
4. This kit contains small parts which may cause choking if misused.
5. Metal wires may contain sharp points, adult assistance required in cutting and bending.
6. To prevent possible short circuits, never touch the contacts inside the battery case with any metal.
7. Only operate after fully assembled.

B. USE OF BATTERIES

1. Requires two 1.5V AA batteries (not included).
2. For best results always use fresh batteries.
3. Make sure you insert the batteries with the correct polarities.
4. Remove the batteries from the kit when not in use.
5. Replace exhausted batteries straight away to avoid possible damage to the kit.
6. Rechargeable batteries must be removed from the kit before recharging.
7. Rechargeable batteries should be recharged under adult supervision.
8. Make sure that the supply terminals in the battery case are not short circuited.
9. Do not attempt to recharge non-rechargeable batteries.
10. Do not mix old and new batteries.
11. Do not mix alkaline, standard (carbon-zinc), or rechargeable (Ni-Cd) batteries.

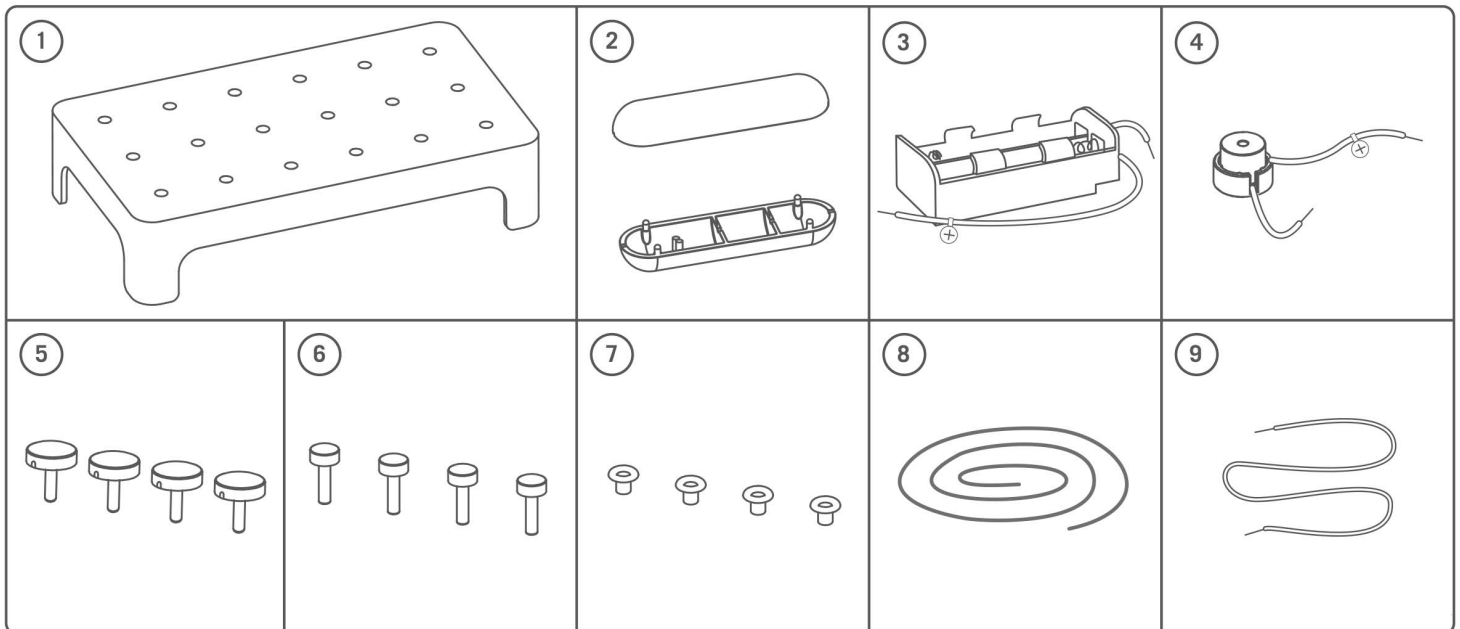

C. CONTENTS

Part 1. Plastic buzz platform, Part 2. Handle, Part 3. Battery case, Part 4. Electric buzzer, Part 5. Big plastic pegs x 4, Part 6. Small plastic pegs x 4, Part 7: Metal pegs x 4, Part 8. Bendable metal wire, Part 9: Insulated wire.

Also required but not provided: 2 x 1.5V AA batteries and 1 wire cutter.

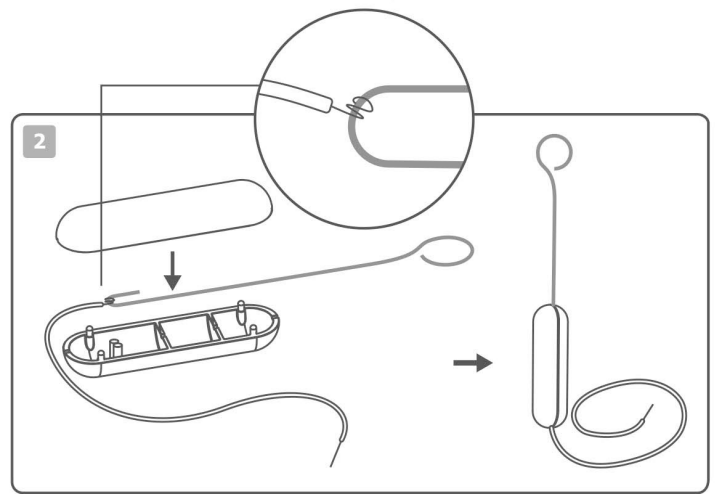
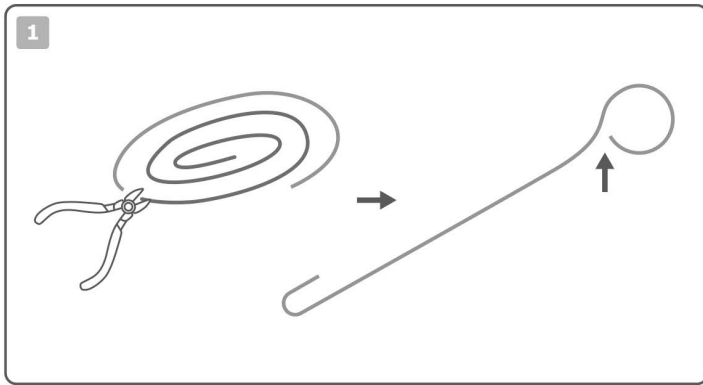

D. ASSEMBLY

1. Cut approximately 20 cm of the metal wire and bend it into the shape of a wand, as shown in the diagram. Leave a gap in the loop to allow this wand to be inserted into the shaped wire (see Step 5).
2. Connect a piece of insulated wire to the smaller end of the wand. Then install the connected wand in the plastic handle, as shown in the diagram.

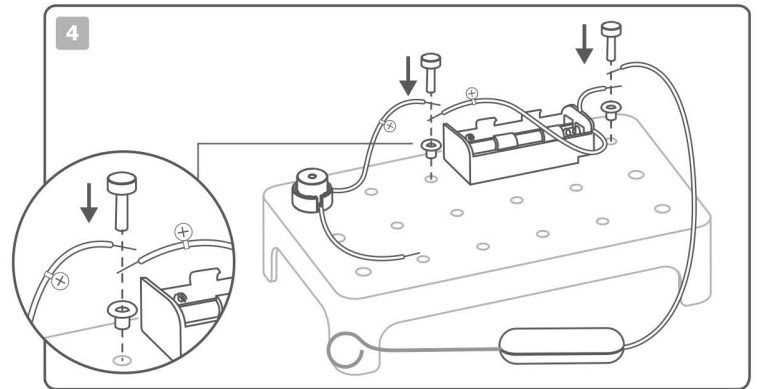
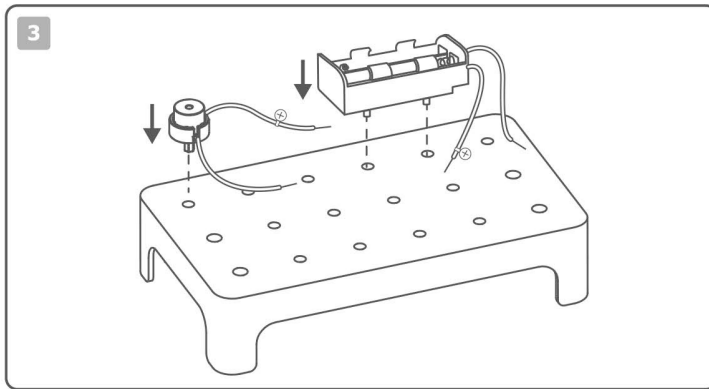

3. Secure the battery case on the platform. Secure the buzzer on the platform next to the battery case.
4. Press a metal peg in any hole between the battery case and buzzer. Connect the two wires labelled "+" from both the buzzer and battery case. Press a small plastic peg to secure the connection. Similarly, connect the remaining wire from battery case with the wire from the wand.

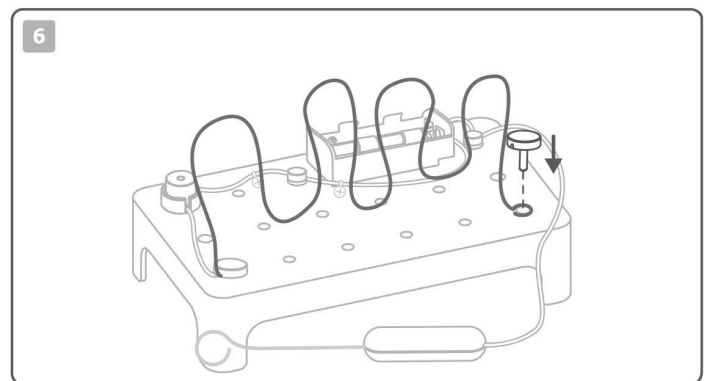
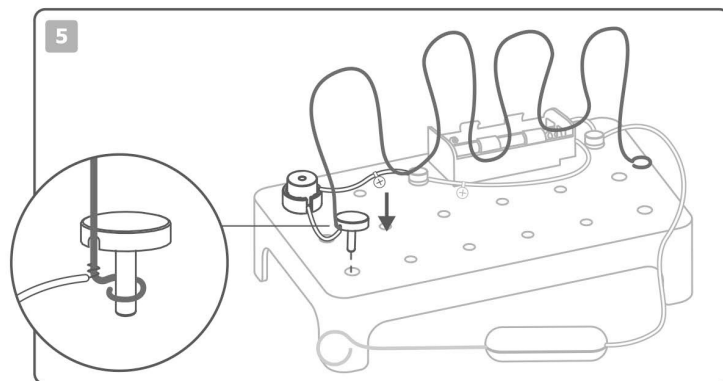

5. Bend the rest of the metal wire into any funny shapes you like. The horizontal span of this shaped wire is about 15 cm. Attach the remaining wire from the buzzer to one end of the shaped metal wire. Wind the end of the metal wire around the pin of a large plastic peg. Secure it on the platform near the buzzer.
6. Wind the other end of the metal wire around the pin of another large plastic peg. Secure it on the platform.

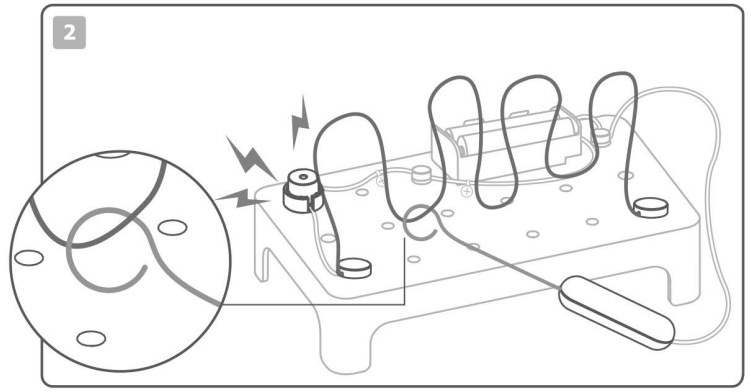
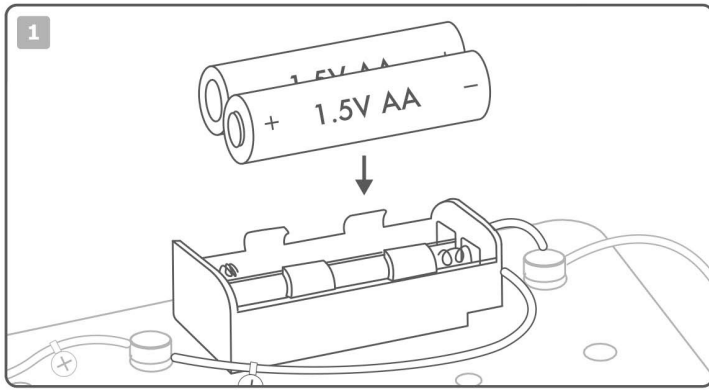

E. OPERATION

1. Install two 1.5V AA batteries in the battery case, with the flat ends against the springs.
2. Insert the wand into the shaped wire through the gap. Hold the handle of the wand and try moving it from one end of the shaped wire to the other end without touching the shaped wire. If the wand touches the shaped wire, a complete electric circuit is formed and the buzzer is "turned on" and makes a BUZZ sound. Challenge your friends or family! The one who gets through the shaped wire without making a buzz in the shortest time will be declared the winner. The fun is unlimited!

F. TROUBLESHOOTING

If the buzzer does not work after assembly, please check the points below:

- If you are using fresh batteries;
- If the batteries are installed according to the correct polarities;
- If all connection points are securely connected; and
- If the wires are correctly connected (see Step D4).

QUESTIONS & COMMENTS:

We treasure you as a customer and your satisfaction with this product is important to us. In case you have any comments or questions, or you find any parts of this kit missing or defective, please do not hesitate to contact our distributor in your country, whose address is printed on the package. You are also welcome to contact our marketing support team at Email: infodesk@4M-IND.com, Fax (852) 25911566, Tel (852) 28936241, Web site: WWW.4M-IND.COM